

## MATERIALS

CASTINGS: MANGANESE BRONZE  
HARDWARE: BRASS OR STAINLESS STEEL  
CUTTER TIP: 01 TOOL STEEL

100% MADE IN USA

INSTRUCTIONS PRINTED IN USA



2500 ROUTER PLANE

WARNING: CUTTER IS SHARP

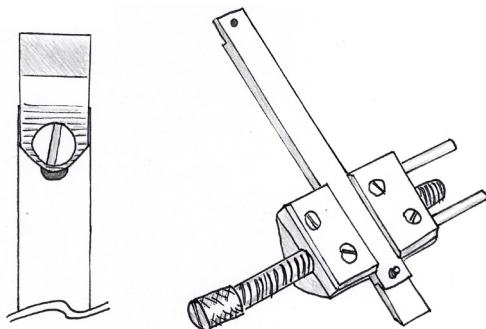
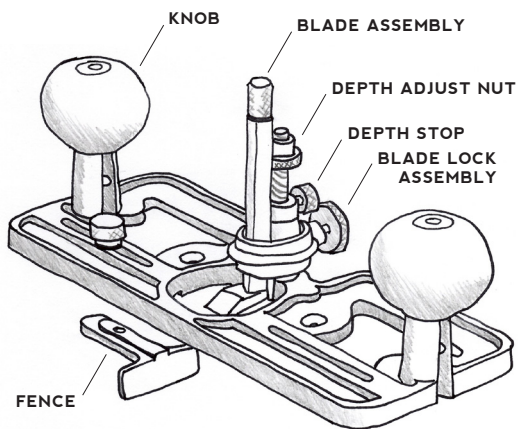

### BLADE POSITIONS:

There are four blade positions, each with a dedicated V-groove to hold the blade assembly. Loosen the blade lock collar until it slides off the router, then remove the blade assembly and depth adjust nut. If moving to one of the outer positions, unscrew the necessary knob, move the nut, blade, and collar to that position.

### ROTATE THE CUTTER HEAD:

To rotate the cutter, loosen the brass nut on the top of the blade assembly. Rotate in 90° increments to the desired orientation. Tighten the brass nut.

### DEPTH OF CUT ADJUSTMENT:

Loosen the blade lock collar just enough to take pressure off the blade assembly. Move the depth adjust nut up or down to raise or lower the cutter. Tighten the blade lock collar, do not over tighten.

### DEPTH STOP:

To use the depth stop, install it below the depth adjust nut. When the nut is set to its final position, raise the depth stop up against it and lock it in position. Raise the depth adjust nut to its initial height to begin the next cut. When the nut reaches the depth stop the final depth of cut has been reached.

### FENCE:

Place the fence in either groove on the sole of the tool. The fence screw and washer drop in through the slot from above to secure the fence in position.